

# Entry Checklist

## STS-107 Flight Supplement

---

**Mission Operations Directorate  
Flight Design and Dynamics Division**

**Final  
February 16, 2001**

National Aeronautics and  
Space Administration

**Lyndon B. Johnson Space Center**  
Houston, Texas



**Verify this is the correct version for the pending operation (training, simulation or flight).**  
Electronic copies of FDF books are available. URL: <http://fltproc.jsc.nasa.gov/dfd>



JSC-48020-107

MISSION OPERATIONS DIRECTORATE

**ENTRY CHECKLIST  
STS-107 FLIGHT SUPPLEMENT**

FINAL  
February 16, 2001

PREPARED BY:

---

Gwendolyn D. Jordan  
Book Manager

APPROVED BY:

---

J. Ken Patterson  
Lead Entry GPO

---

Gregory T. Oliver  
Chief, Ascent/Descent  
Dynamics Branch

This document is under the configuration control of the Crew Procedures Control Board (CPCB). All proposed changes must be submitted on JSC Form 482 to DO3/FDF Manager.

Additional distribution of this book for official use must be requested in writing to DO3/FDF Manager. The request must include justification and requester's name, organization, position, and phone number. Contractor requests are made through the NASA or DOD organization supported. Deletions, reduction in quantity, or change of address may be submitted to DO3/FDF Management Office, 281-244-1184.

ENT/107/FIN

Incorporates the following:
482#: None

AREAS OF TECHNICAL RESPONSIBILITY

Book Manager	DM43/G. Jordan	281-483-1261
Deorbit Burn to Entry Interface	DM43/J. Patterson	281-483-1987
Contingency Procedures and Entry Interface thru Rollout	DM43/J. Patterson	281-483-1987

NOTE

This Flight Supplement must be integrated into the generic Entry Checklist to have a complete document for flight. Insert the Flight Supplement (FS) pages in the proper numerical order in the generic Entry Checklist by using the List of Effective Pages (LOEP) which provides the sequence for merging pages to create a complete Entry Checklist

ENTRY CHECKLIST  
STS-107 FLIGHT SUPPLEMENT

**LIST OF EFFECTIVE PAGES**

FINAL            02/16/01  
PCN-1            03/12/02

Sign Off .....	* generic	3-7 .....	generic
ii .....	* generic	3-8 .....	generic
Sign Off .....	* 107/FIN	3-9 .....	generic
FS iv .....	* 107/FIN	3-10 .....	generic
v .....	* generic	3-11 .....	generic
vi .....	* generic	3-12 .....	generic
vii .....	* generic	3-13 .....	generic
viii .....	* generic	3-14 .....	generic
ix .....	* generic	3-15 .....	generic
x .....	* generic	3-16 .....	generic
FS xi .....	* 107/FIN 1	3-17 .....	generic
FS xii .....	* 107/FIN 1	3-18 .....	generic
FS xiii .....	* 107/FIN 1	3-19 .....	generic
FS xiv .....	* 107/FIN	3-20 .....	generic
xv .....	generic	3-21 .....	generic
xvi .....	generic	3-22 .....	generic
1-1 (3 pgs) .....	† generic	3-23 .....	generic
1-2 (3 pgs) .....	† generic	3-24 .....	generic
2-1 .....	generic	3-25 .....	generic
2-2 (6 pgs) .....	† generic	3-26 .....	generic
2-3 (6 pgs) .....	† generic	3-27 .....	generic
2-4 .....	generic	3-28 .....	generic
FS 2-5 .....	107/FIN	FS 3-29 .....	107/FIN
FS 2-6 .....	107/FIN 1	FS 3-30 .....	107/FIN
FS 3-1 .....	107/FIN	3-31 .....	generic
FS 3-2 .....	107/FIN 1	3-32 .....	generic
FS 3-3 .....	107/FIN 1	FS 3-33 .....	107/FIN 1
FS 3-4 .....	107/FIN	FS 3-34 .....	107/FIN 1
3-5 .....	generic	3-35 .....	generic
3-6 .....	generic	3-36 .....	generic

\* - Omit from flight book  
† - Extra pages in crew copy only

3-37	generic	5-16	generic
3-38	generic	5-17	generic
3-39	generic	5-18	generic
3-40	generic	FS 5-19	107/FIN 1
3-41	generic	FS 5-20	107/FIN
3-42	generic	5-21	generic
3-43	generic	5-22	generic
3-44	generic	5-23	generic
4-1	generic	5-24	generic
4-2	generic	6-1	generic
4-3	generic	6-2	generic
4-4	generic	6-3	generic
4-5	generic	6-4	generic
4-6	generic	7-1	* generic
FS 4-7	107/FIN	7-2	* generic
FS 4-8	107/FIN	7-3	* generic
4-9	generic	7-4	* generic
4-10	generic	7-5	* generic
FS 4-11	107/FIN 1	7-6	* generic
FS 4-12	107/FIN	7-7	* generic
4-13	generic	7-8	* generic
4-14	generic	7-9	* generic
4-15	generic	7-10	* generic
4-16	generic	8-1	* generic
5-1	generic	CC 8-2	* generic
5-2	generic	CC 8-3	* generic
5-3	generic	CC 8-4	* generic
5-4	generic	CC 8-5	* generic
5-5	generic	CC 8-6	* generic
5-6	generic	CC 8-7	* generic
5-7	generic	CC 8-8	* generic
5-8	generic	CC 8-9	* generic
5-9	generic	CC 8-10	* generic
5-10	generic	CC 8-11	* generic
5-11	generic	CC 8-12	* generic
5-12	generic	CC 8-13	* generic
5-13	generic	CC 8-14	* generic
5-14	generic	CC 8-15	* generic
5-15	generic	CC 8-16	* generic

\* – Omit from flight book

CC 8-17 ..... \* generic  
CC 8-18 ..... \* generic  
CC 8-19 ..... \* generic  
CC 8-20 ..... \* generic  
CC 8-21 ..... \* generic  
8-22 ..... \* generic  
FS CC 8-23 ... \* 107/FIN  
FS CC 8-24 ... \* 107/FIN

\* – Omit from flight book

ENTRY CUE CARDS

<u>Title</u>	<u>Ref. Page</u>	<u>Card No.</u>
Deorbit Burn Flight		
Rules (Front) . . . . .	CC 8-2	generic
(Back) . . . . .	CC 8-3	generic
Deorbit Burn (RCS)		
(Front) . . . . .	CC 8-4	generic
(Back) . . . . .	CC 8-6	generic
Deorbit Burn (2 Eng)		
(Front) . . . . .	CC 8-8	generic
Deorbit Burn (1 Eng)		
(Back) . . . . .	CC 8-10	generic
Unbalanced Prplt		
Deorbit Burn		
(Front) . . . . .	CC 8-12	generic
Deorbit Burn (Mixed		
Xfeed) (Back) . . . . .	CC 8-14	generic
Entry Maneuvers		
(Front) . . . . .	CC 8-16	generic
(Back) . . . . .	CC 8-17	generic
Entry NO-GO Checklist		
(Front) . . . . .	CC 8-18	generic
ADTA Mgmt (Back) . . . . .	CC 8-19	generic
Mach $\alpha$		
(Front) . . . . .	CC 8-20	generic
(Back) . . . . .	CC 8-20	generic
Entry Control		
(Front) . . . . .	CC 8-21	generic
(Back) . . . . .	CC 8-22	generic
Deorbit Burn Monitor		
(Front) . . . . .	FS CC 8-23	ENT-2a/107/A,O,D,E/A
OMS Failures (Back) . . . . .	FS CC 8-24	ENT-2b/107/A,O,D,E/A



OMS/  
RCS ΔV

OMS/RCS ΔV

FS 2-5

ENT/107/FIN

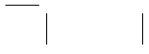

**OMS He PRESS/ $\Delta$ V/BURN TIME**

OMS/  
RCS  $\Delta$ V

OMS% GAGE	OMS He Press *	OMS $\Delta$ V	RCS $\Delta$ V	RCS BURN MIN:SEC
50	3500	250	207	7:25
40	3100	196	163	5:49
38	3020	185	154	5:30
36	2940	174	145	5:11
34	2860	164	136	4:52
32	2780	153	128	4:32
30	2700	142	119	4:13
28	2620	131	110	3:54
26	2540	120	101	3:35
24	2460	109	92	3:16
22	2380	98	83	2:56
20	2300	88	74	2:37
18	2220	77	65	2:18
16	2140	66	56	1:58
14	2060	55	46	1:39
12	1980	44	37	1:19
10	1900	33	28	0:59
8	1820	22	19	0:39
6	1740	11	9	0:20
5	1700	5	5	0:10

\* He pressure not valid until 1 hr after last burn

<b><math>\Delta</math>V CAPABILITY</b>	
ARCS $\Delta$ V fps =	$0.8 \times [L\% + R\% - \text{AFT QTY } 1]$
FRCS $\Delta$ V fps =	$0.8 \times \text{FRCS } \%$
OMS $\Delta$ V fps =	$5.4 \times \text{OMS } \%$

NOTE: Uses assumed vehicle weight of 243,775 lb

DEORBIT BURN

DEORBIT  
BURN

FS 3-1

ENT/107/FIN

**STS-107  
LANDING SITE TABLE  
(OPS 1/6/3)  
(31° to 49.9° INCLINATION)**

**DEORBIT  
BURN**

S I T E	LOCATION	RWY	TACANS		MLS CH	LG
				ITEM 5		
1	KSC	KSC 15 KSC 33	TTS 59Y	OMN 73	8 6	15000 15000
2	BEN GUERIR	BEN 36 BEN 18	◆BEN 108	CBA 116(DME)	◆6 -	13720 12720
3	MORON AB	MRN 20 MRN 02	MRN 100	AOG 23	◆6 -	11929 11729
4	ZARAGOZA	ZZA 30L ZZA 12R	ZZA 64	ZZA 77 (DME)	◆6 -	12397 12197
5	BANJUL INT'L	BYD 32 BYD 14	◆BYD 121	BJ 76 (DME)	◆6 -	12016 11816
6	BERMUDA	BDA 30 BDA 12	BDA 86 (DME)	BDA 86 (DME)	- -	8892 9212
7	AMILCAR CABRAL	AML 01 AML 19	CVS 100 (DME)	CVS 100 (DME)	- -	9728 9728
8	LAS PALMAS MONROVIA	GDV 03L LRB 04	TGN 103 -	- ROB 85 (DME)	- -	9827 10000
9	LAJES	LAJ 15 LAJ 33	LAJ 45	TRM 109	- -	10870 10870
10	HOEDSPRUIT	AHS 18 AHS 36	HSV 87	HSV 87	- -	12256 12821
11	*BEN GUERIR TAMANRASSET	BEN 36 AAT 02	◆BEN 108 -	- TMS 72 (DME)	◆6 -	13720 10870
12	*MORON AB SOUDA	MRN 20 GSA 29	MRN 100 -	- RKL 20	◆6 -	11929 11786
13	*ZARAGOZA ORLANDO	ZZA 30L MCO 18R	ZZA 64 -	- TTS 59Y	◆6 -	12397 11204

◆ Available for TAL Only

FADS version OR101

\*Reduced Crossrange TAL Site

**STS-107  
LANDING SITE TABLE  
(OPS 1/6/3)  
(31° to 49.9° INCLINATION)**

S I T E	LOCATION	RWY	TACANS		MLS CH	LG
				ITEM 5		
14	KING KHALID DIEGO GARCIA	KKI 15R JDG 31	RIY 92	-	-	13164
			-	NKW 57	-	12003
15	AMBERLEY TINDAL	AMB 15 PTN 14	AMB 94	-	-	9200
			-	TDL 70	-	9003
16	ANDERSEN AFB HAO	GUA 06L HAO 12	UAM 54	-	-	10555
			-	HAO 85 (DME)	-	10089
17	HONOLULU	HNL 08R HNL 26L	HNL 95	CKH 86	-	11000
					-	11000
18	DYESS AFB	DYS 16 DYS 34	ABI 84	MQP 124	-	13500
					-	13500
19	NASSAU INT'L	YNN 14 YNN 32	ZQA 74 (DME)	ZQA 74 (DME)	-	10293
					-	10230
20	NORTHROP	NOR 17 NOR 23	SNG 121Y	HMN 92	6	15000
					6	15000
21	NORTHROP	NOR 05 NOR 35	SNG 121Y	HMN 92	-	15000
					-	15000
22	EDWARDS AFB	EDW 15 EDW 33	EDW 111	LHS 21	6	16300
					#	16300
23	EDWARDS AFB	EDW 22 EDW 04	EDW 111	LHS 21	8/†	14995
					6	13995
24	EDWARDS AFB	EDW 23L EDW 18L	EDW 111	LHS 21	#	15000
					#	15000
25	KSC	KSC 15 KSC 33	COF 97	LAL 107	8	15000
					6	15000

# MSBLS Jr. Channel 6 - Requires Uplink FADS version OR101

† MSBLS Jr. Channel 8 - Requires Uplink

— | |

| | —

This Page Intentionally Blank

FS 3–4

ENT/107/FIN

— | |

| | —

## DEORBIT BURN MONITOR

<b>OMS TEMP*</b> FU IN P $\geq$ <table border="1" style="display: inline-table; vertical-align: middle;"> <tr><td style="padding: 2px;">L</td><td style="padding: 2px;">R</td></tr> <tr><td style="padding: 2px;">225</td><td style="padding: 2px;">221</td></tr> <tr><td style="padding: 2px;">211</td><td style="padding: 2px;">200</td></tr> </table> $\leq$ or No FU IN P	L	R	225	221	211	200	<table border="1" style="display: inline-table; vertical-align: middle;"> <tr><td style="padding: 2px;">L</td><td style="padding: 2px;">R</td></tr> <tr><td style="padding: 2px;">225</td><td style="padding: 2px;">221</td></tr> <tr><td style="padding: 2px;">211</td><td style="padding: 2px;">200</td></tr> </table> Oms Eng Fail Oms PRPLT Fail	L	R	225	221	211	200	Oms Eng Fail Oms PRPLT Fail
L	R													
225	221													
211	200													
L	R													
225	221													
211	200													
<b>Oms PC* &amp; Oms</b> ↓ (BFS: ✓ accel) ENG VLV 1 or 2 < 70 or OX IN P > 227 OX IN P $\leq$ 227 or No OX IN P	Oms Eng Fail Oms PRPLT Fail	Oms Eng Fail Oms PRPLT Fail												
<b>Oms OX/FU TK P</b> (✓ ENG IN P) OX/FU LOW  OX & FU HIGH	He PRESS/VAP ISOL (two) – OP If aff TK P not incr: He PRESS/VAP ISOL (two) – CL At PC < 72 or Oms TEMP: Oms PRPLT Fail  He PRESS/VAP ISOL (two) – CL Cycle He A(B) to maintain TK P 234–284	He PRESS/VAP ISOL (two) – OP If aff TK P not incr: He PRESS/VAP ISOL (two) – CL At PC < 72 or Oms TEMP: Oms PRPLT Fail  He PRESS/VAP ISOL (two) – CL Cycle He A(B) to maintain TK P 234–284												
<b>Oms GMBL</b> PRI fail SEC fail	L(R) Oms GMBL – SEC (twice) If high RCS usage: Oms Eng Fail	L(R) Oms GMBL – SEC (twice) If high RCS usage: Oms Eng Fail												
<b>GPC</b> <b>1(4) &amp;</b> Burning Oms aff  SEC GMBL lost 2 FAs lost	aff GPC PWR – OFF If SEC GMBL avail: aff MDM FF 1(4) – OFF, ON L(R) Oms GMBL – SEC (twice) If high RCS usage: Oms Eng Fail ✓ MAN SHUTDN	aff GPC PWR – OFF If SEC GMBL avail: aff MDM FF 1(4) – OFF, ON L(R) Oms GMBL – SEC (twice) If high RCS usage: Oms Eng Fail ✓ MAN SHUTDN												
<b>I/O ERROR FA</b>  2 FAs lost	<b>1(4)</b> L(R) Oms GMBL – SEC I/O RESET (if recov: BFS I/O RESET) If high RCS usage: Oms Eng Fail ✓ MAN SHUTDN	L(R) Oms GMBL – SEC I/O RESET (if recov: BFS I/O RESET) If high RCS usage: Oms Eng Fail ✓ MAN SHUTDN												
<b>BCE STRG D</b>  <b>1(4)</b>	I/O RESET (if recov: >>) If high RCS usage: L(R) Oms GMBL – SEC (twice)	I/O RESET (if recov: >>) If high RCS usage: L(R) Oms GMBL – SEC (twice)												
<b>RM DLMA IMU</b> or <b>GPC SET SPLIT</b> or <b>2 MN BUSES</b>	<b>ABOVE SAFE</b> HP ⇒ <table border="1" style="display: inline-table; vertical-align: middle;"> <tr><td style="width: 20px; height: 20px;"></td><td style="width: 20px; height: 20px;"></td></tr> </table>  <b>BELOW SAFE</b> HP ⇒			STOP BURN: Oms Eng(s) – OFF >>  IMU DLMA: After C/O: ✓ timer <table border="1" style="display: inline-table; vertical-align: middle;"> <tr><td style="padding: 2px;">G21</td></tr> </table> If any IMU ACC > 0.03: aff IMU – desel I'cnct Oms to RCS (✓ RCS Burn Time) THC +X to TGT HP (EOM) or 3.5 x timer at C/O (AOA) SET SPLIT: Go to "GPC" above	G21									
G21														
<b>I/O ERROR PCM</b>	OI PCMMU PWR – 2(1)	OI PCMMU PWR – 2(1)												

\*If XFD, BLDN, or sensor fail, monitor ENG IN P for off-nominal performance

ENT–2a/107/A,O,D,E/A

MS ONLY

FS 3–29

ENT/107/FIN

## OMS FAILURES

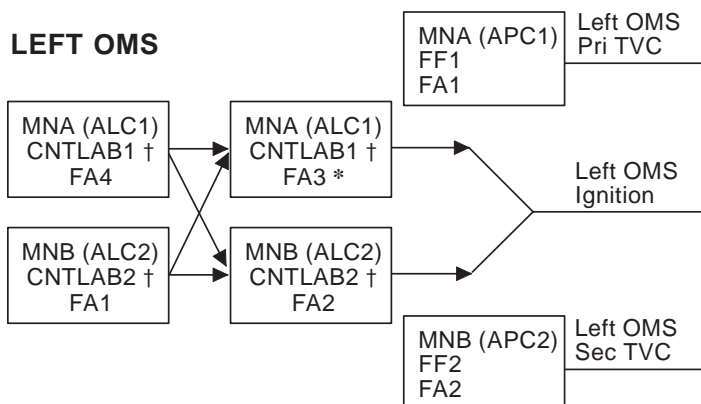

† If CNTL AB1 or AB2 (CA1 or CA2) failed and ign path still exists at OMS fail, assume L(R) OMS ↓ is PRPLT FAIL

\* If L(R) Pc failed high during burn or FA3(4) failed, at L(R) OMS fail, no guidance downmode after L(R) OMS ENG switch OFF (TGO slow, ADI needles in error, 6 ft/s underburn)

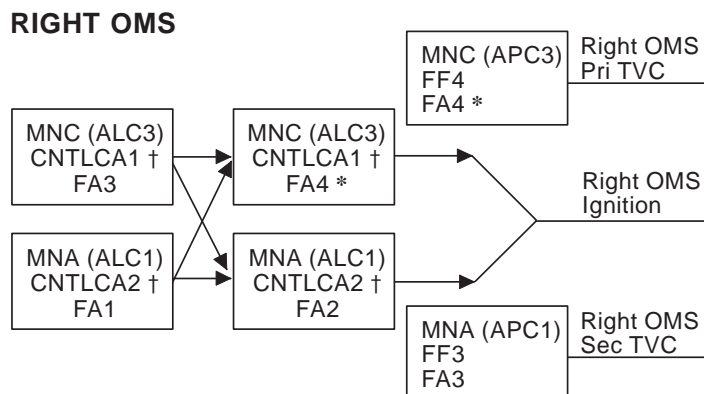

If two FA MDMs lost		
MDMs	Preburn: ENG – OFF	During burn: MAN SHUTDN
1,2	LEFT (TVC)	BOTH
1,3	RIGHT (IGN)	LEFT
1,4	LEFT (IGN)	RIGHT
2,3	LEFT (IGN)	RIGHT
2,4	RIGHT (IGN)	LEFT
3,4	RIGHT (TVC)	BOTH

ENT-2b/107/A,O,D,E/A

1: GNC DEORB MNVR EXEC	2: GNC DEORB MNVR EXEC
3: BFS, GNC SYS SUMM 2	

- \* **UNDERBURN** \*
- \* Determine  $\Delta$ HP \*
- \* (CUR HP – TGT HP) \*
- \* Record UNDERBURN prebank on \*
- \* ENTRY MANEUVERS Cue Card \*

\* **PREBANK TABLE EDW (HA = 139NM)** \*

$\Delta$ HP	0	3	(7)	RED	11	14	17	20	23
PREBANK	0	45	85	NOR	105	120	130	150	175
NOR NOT AVAIL.									



$\Delta$ HP	8	12	(17)	22	26	31
PREBANK	65	80	95	115	135	175
<b>G50</b> ITEM 41 + 20, $\sqrt$ RWY 17 SET TACAN tw (three) 121Y						

\* **PREBANK TABLE KSC (HA = 140 NM)** \*

$\Delta$ HP	0	3	(7)	10	13	16	19	22	25
PREBANK	0	45	85	100	110	115	125	145	175
Set TACAN tw (three) 59Y									

$\Delta$ HP									
PREBANK									

**POST BURN STATUS**

NOMINAL

$\Delta$  TIG

		:		
--	--	---	--	--

1: GNC DEORB MNVR EXEC	2: GNC DEORB MNVR EXEC
3: BFS, GNC SYS SUMM 2	

If non-MEDS vehicle:

C F6 INST PWR – FLT/MPS  
P F7 MPS PRESS He Sel – REG

C CRT1 **GNC, OPS 303 PRO**

1: GNC DEORB MNVR COAST	2: GNC DEORB MNVR COAST
-------------------------	-------------------------

C CRT1 ✓Uplinked INRTL EI-5 MM303 ATT with DEL PAD

\* If no deorbit TGT uplink, enter INRTL EI-5 \*  
\* MM303 ATT from DEL PAD \*  
\* R – ITEM 24 + \_\_\_\_\_ \*  
\* P – ITEM 25 + \_\_\_\_\_ \*  
\* Y – ITEM 26 + \_\_\_\_\_ \*

Mnvr to EI-5 ATT – ITEM 27 EXEC

	TIME to EI (min)	LVLH PITCH (deg)
	20	339
		343
* If UNDERBURN or no *		347
* DEL PAD, manually *		351
* mnvr to LVLH R 001; *		355
* Y 358, P per table *	15	359
		3
		7
		11
		15
	10	19
		23
		27
		31
		35
	5	39

C **OMS GMBL PWRDN (PASS ONLY)**

CRT1 Verify GMBL positions:

	<u>L</u>	<u>R</u>
P	+5.9	+5.9
Y	+6.4	-6.4

GMBL OFF – ITEM 32 EXEC  
– ITEM 33 EXEC

FS 3-34

ENT/107/FIN 1

— | |

| | —

This Page Intentionally Blank

MS ONLY

FS 4–7

ENT/107/FIN

— | |

| | —

— | |

| | —

This Page Intentionally Blank

MS ONLY

FS 4–8

ENT/107/FIN

— | |

| | —

## ENTRY ALPHA

VR	$\alpha_{ref}$	R	H	Href	Rref
25	40	4442	400		
24	HI 40 LO	2777	249	-43	R82
23	43 40 37	2273	240	-59	72
22	43 40 37	1893	234	-76	65
21	43 40 37	1587	227	-97	61
20	43 40 37	1352	221	-112	60
19	43 40 37	1157	214	-133	59
18	43 40 37	1001	207	-156	61
17	43 40 37	875	200	-174	61
16	43 40 37	771	193	-186	63

## KSC 15

MAX L/D	
M	$\alpha$
3	17
2	15
1	12

ASC-14b/107/A,E/B

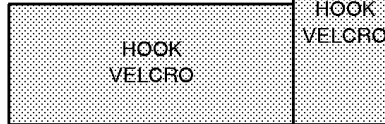

107 OCFR1 CY

15	43 40 37	684	187	-199	64
14	43 40 37	612	181	-127	L62
13	43 40 37	546	179	-136	59
12	43 40 37	484	174	-152	57
11	42 39 36	426	168	-194	56
10	41 38 35	373	162	-174	51
9	39 36 33	322	157	-208	47
8	37 34 31	275	150	-240	43
7	33 30 27	227	141	-269	R40
6	30 27 24	184	130	-272	39
5	26 23 20	142	117	-272	40
4	23 20 18	105	103	-264	41
3	19 16 15	75	90	-247	L32
2.5	14	61	82	-263	
2	12	50	76	-274	
1.5	10	38	66	-324	
1	8	28	52	-260	

— | |

| | —

This Page Intentionally Blank

MS ONLY

FS 4–12

ENT/107/FIN

— | |

| | —

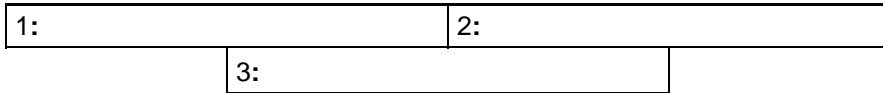

## POST LANDING PAYLOAD ACTIVITIES

### NOTE

Switch throw to occur no earlier than crew egress in order to maintain crew comfort and is desired no later than 1 hr to maintain Spacehab experiment thermal requirements

L1      After crew egress and within 1 hr of wheelstop:  
            FLOW PROP VLV LOOP 1 – PL HX (tb-PL)      |

This Page Intentionally Blank

TOP

HOOK  
VELCRO

**DEORBIT  
BURN  
MONITOR**

HOOK  
VELCRO

<b>OMS TEMP*</b>	<b>L R</b>	
FU IN P $\geq$	225	221
	211	200
or No FU IN P		
		OMS ENG FAIL
		OMS PRPLT FAIL
<b>OMS PC* &amp; OMS ↓</b> (BFS: $\checkmark$ accel)		
ENG VLV 1 or 2 $<$ 70		OMS ENG FAIL
or OX IN P $>$ 227		
OX IN P $\leq$ 227		OMS PRPLT FAIL
or No OX IN P		
<b>OMS OX/FU TK P</b> ( $\checkmark$ ENG IN P)		
OX/FU LOW		He PRESS/VAP ISOL (two) – OP
		If aff TK P not incr:
		He PRESS/VAP ISOL (two) – CL
		At PC $<$ 72 or OMS TEMP:
		OMS PRPLT FAIL
OX & FU HIGH		He PRESS/VAP ISOL (two) – CL
		Cycle He A(B) to maintain TK P 234–284
<b>OMS GMBL</b>	PRI fail	L(R) OMS GMBL – SEC (twice)
	SEC fail	If high RCS usage: OMS ENG FAIL
<b>GPC</b>	<b>1(4) &amp;</b> Burning OMS aff	aff GPC PWR – OFF
		If SEC GMBL avail:
		aff MDM FF 1(4) – OFF, ON
		L(R) OMS GMBL – SEC (twice)
	SEC GMBL lost	If high RCS usage: OMS ENG FAIL
	2 FAs lost	$\checkmark$ MAN SHUTDN
<b>I/O ERROR FA</b>	<b>1(4)</b>	L(R) OMS GMBL – SEC
		I/O RESET (if recov: BFS I/O RESET)
		If high RCS usage: OMS ENG FAIL
	2 FAs lost	$\checkmark$ MAN SHUTDN
<b>BCE STRG D</b>	<b>1(4)</b>	I/O RESET (if recov: $>>$ )
		If high RCS usage:
		L(R) OMS GMBL – SEC (twice)
<b>RM DLMA IMU</b> or <b>GPC SET SPLIT</b> or <b>2 MN BUSES</b>	<b>ABOVE SAFE</b> HP $\Rightarrow$ <input type="checkbox"/>	STOP BURN: OMS ENG(s) – OFF $>>$
	<b>BELOW SAFE</b> HP $\Rightarrow$	IMU DLMA:
		After C/O: $\checkmark$ timer <input type="checkbox"/> G21
		If any IMU ACC $>$ 0.03: aff IMU – desel
		I'cnct OMS to RCS ( $\checkmark$ RCS Burn Time)
		THC +X to TGT HP (EOM) or
		3.5 x timer at C/O (AOA)
		SET SPLIT: Go to "GPC" above
<b>I/O ERROR PCM</b>		OI PCMMU PWR – 2(1)

\*If XFD, BLDN, or sensor fail, monitor ENG IN P for off-nominal performance

ENT-2a/107/A,O,D,E/A

(reduced copy)

FAB USE ONLY

FS CC 8-23

ENT/107/FIN

TOP  
BACK OF 'DEORBIT BURN MONITOR'

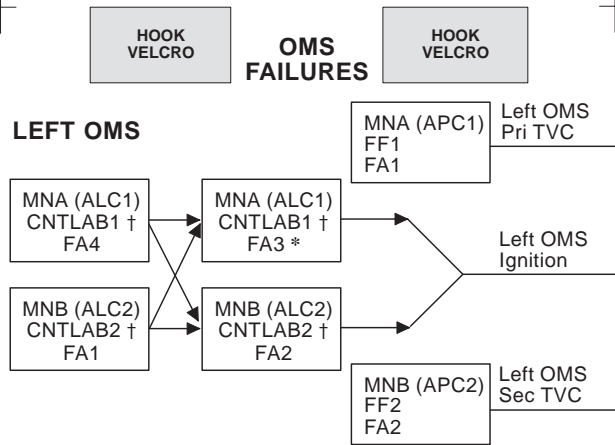

† If CNTL AB1 or AB2 (CA1 or CA2) failed and ign path still exists at OMS fail, assume L(R) OMS ↓ is PRPLT FAIL  
 \* If L(R) Pc failed high during burn or FA3(4) failed, at L(R) OMS fail, no guidance downmode after L(R) OMS ENG switch OFF (TGO slow, ADI needles in error, 6 ft/s underburn)

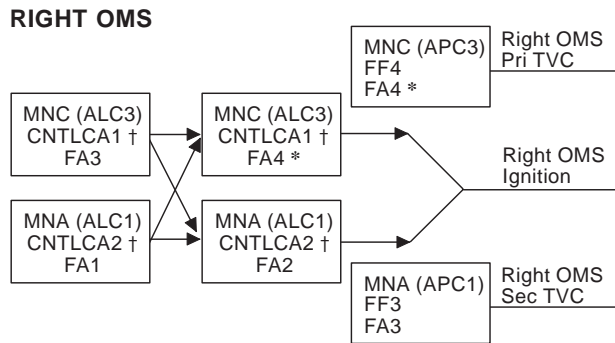

If two FA MDMs lost		
MDMs	Preburn: ENG - OFF	During burn: MAN SHUTDN
1,2	LEFT (TVC)	BOTH
1,3	RIGHT (IGN)	LEFT
1,4	LEFT (IGN)	RIGHT
2,3	LEFT (IGN)	RIGHT
2,4	RIGHT (IGN)	LEFT
3,4	RIGHT (TVC)	BOTH

ENT-2b/107/A,O,D,E/A

(reduced copy)

Space Shuttle Program  
**FLIGHT DATA FILE**

JSC-48020-107  
**FINAL**

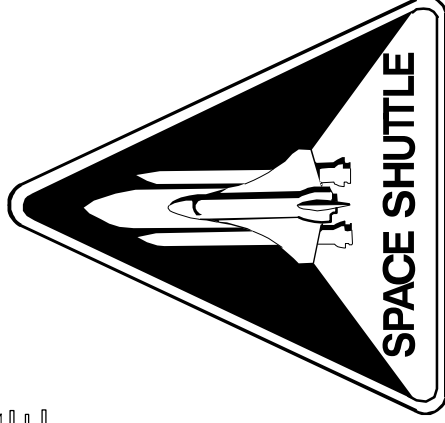

<b>ENTRY CHECKLIST</b>	<b>STS 107</b>
----------------------------	--------------------

Flight Cover (trim bottom to expose tabs)