

2.22 SPACEHAB

CONTENTS

Description	2.22-1
Configurations	2.22-1
Flight Deck Interfaces	2.22-2
Command and Data Subsystem	2.22-3
Caution and Warning	2.22-3
Electrical Power Subsystem	2.22-3
Environmental Control Subsystem.....	2.22-3
Audio Communication Subsystem.....	2.22-4
Fire Suppression Subsystem	2.22-4
Closed Circuit Television Subsystem.....	2.22-4

Description

The Spacehab module is a pressurized experiment carrier designed to augment space shuttle middeck experiment accommodations. The Spacehab system consists of a module flown in the orbiter payload bay that is configured with middeck-type lockers, racks, and/or the logistics transportation system (LTS) to accommodate a variety of experiments and equipment. The Spacehab module provides space for crewmembers to work on experiments in a shirt-sleeve environment. Spacehab offers the Space Shuttle Program three module configurations to accommodate mission-specific requirements.

Configurations

Spacehab configuration 1 is connected to the orbiter using a modified Spacelab tunnel adapter and standard orbiter payload support resources from the cabin and payload bay. The Spacehab single module to orbiter tunnel adapter connection is accomplished using the Spacehab tunnel adapter, the Spacehab transition section, and the Spacelab flex section. The Spacehab module provides crewmembers with a place to carry out their experiments and contains cooling, power, and command and data provisions, in addition to Spacehab housekeeping systems (i.e., power distribution and control, lighting, fire and smoke detection, fire suppression, atmosphere control, status monitoring and control, and thermal control).

Spacehab configuration 2 allows the Spacehab single module to be mounted in a new trunnion location to accommodate the orbiter docking system (ODS). The module is connected to the ODS using a Spacelab flex section, the new Spacelab extension for Mir, the Spacehab long tunnel segment, the Spacelab tunnel segment, and another flex section. All Spacehab module subsystems remain the same as configuration 1, except for a lower air exchange rate with the orbiter and the addition of two negative pressure relief valves (NPRVs).

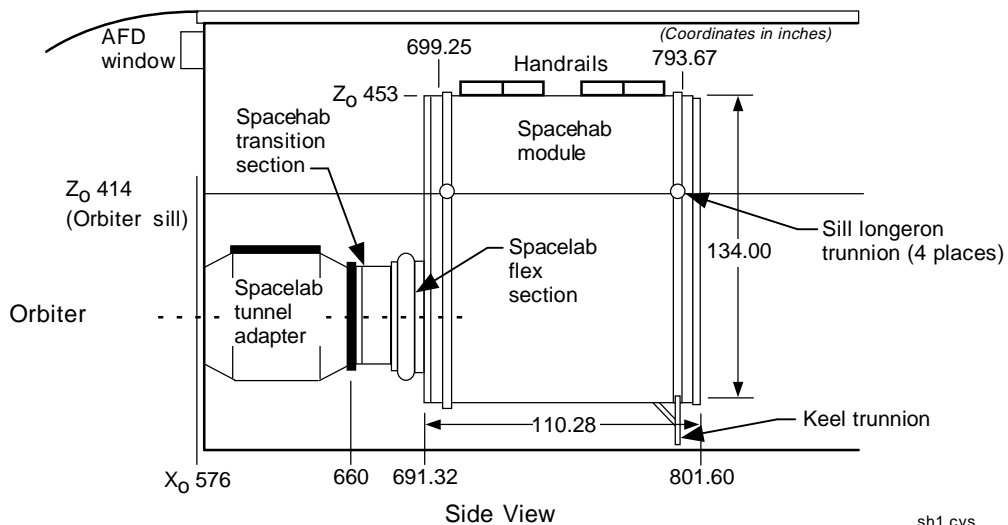

Spacehab Configuration 1

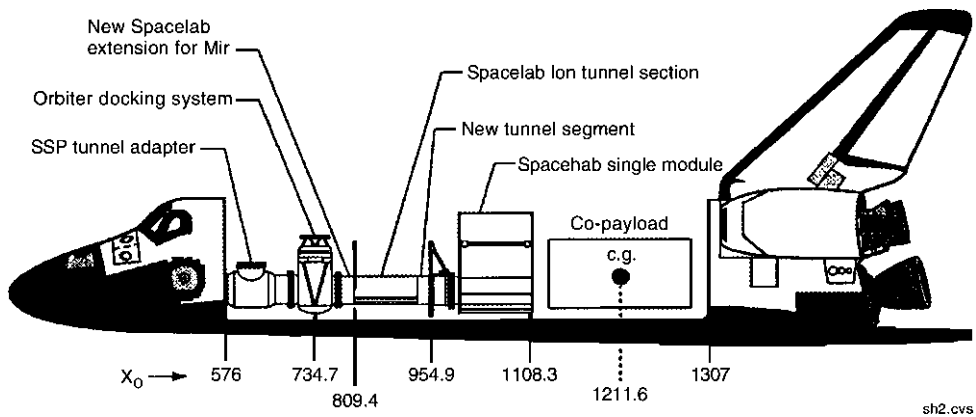

Spacehab Configuration 2

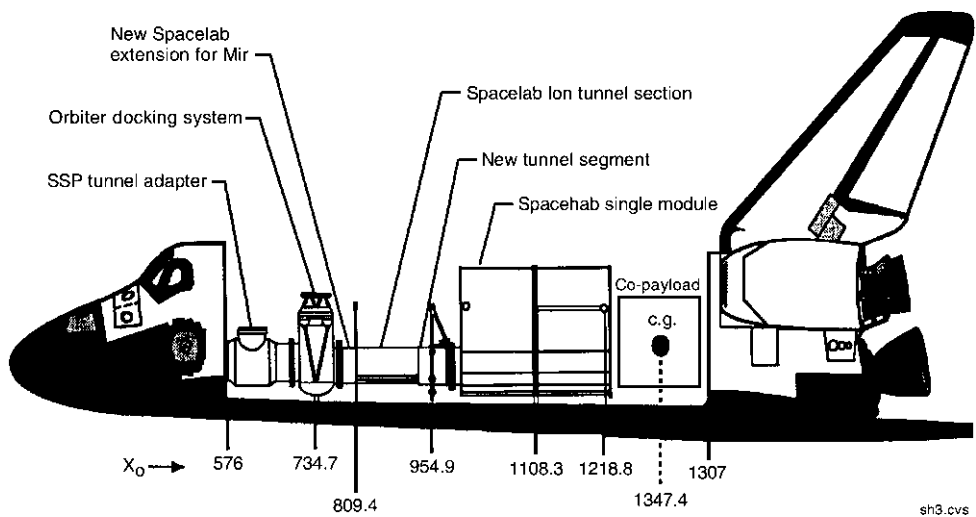

Spacehab Configuration 3

Spacehab configuration 3 is a double module, consisting of one Spacehab module and one Spacehab module shell that are jointed by an intermediate adapter. Configuration 3 has the same tunnel configuration and attach points as configuration 2, except for two trunnions that are moved further aft to accommodate the additional module. All Spacehab module subsystems remain the same as configuration 2, except for the addition of a dc fan and lights in the aft module segment.

Flight Deck Interfaces

Several panels located on the flight deck allow the crew to control and monitor Spacehab subsystems operations. Those interfaces are listed below with brief descriptions of their primary functions.

R1 Panel

- The R1 panel controls the connection of main dc power to the Spacehab via the primary payload bus.
- The R1 panel controls the connection of essential and emergency power to the Spacehab via auxiliary payload bus and aft payload B bus.
- The R1 panel controls the connection of aft flight deck dc power to the Spacehab for system operations.

L1 Panel

- The L1 panel controls the distribution of orbiter Freon flow to the payload heat exchanger to support Spacehab thermal load requirements.

C3A5

- The C3A5 panel provides controls to activate the Spacehab fire suppression subsystem (FSS) and H₂O line heaters.

CRT

- The orbiter CRT allows the crew to monitor and control Spacehab subsystems via the Spacehab displays and SPECS (BFS display 206 SH Launch/Entry, SM SPEC 210 SH ACT/DEAC, and SM SPEC 215 SH ECS).

L12 Panel

- The L12 panel consists of the standard switch panel (SSP) configurations to support Spacehab activation, control, and monitoring.

Command and Data Subsystem

The Spacehab command and data subsystem (CDS) receives hardwired commands from the orbiter SSP and Spacehab monitor and control panel. The CDS can receive commands for Spacehab subsystem and experiment activation and deactivation from either ground uplink or the orbiter CRT via the payload signal processor (PSP) link. The Spacehab can also receive commands from an orbiter-provided microcomputer, the payload general support computer (PGSC). The PGSC commanding capability can be used only to command the Spacehab video switching unit (VSU).

The data management unit (DMU) is the major element of the Spacehab CDS. The DMU provides data acquisition and command functions for the Spacehab module. The DMU also provides all serial interfaces required for data transmission between the Spacehab module and the orbiter.

The payload data interleaver (PDI) interface to the DMU gives ground controllers the capability to monitor Spacehab subsystem and experiment telemetry.

Caution and Warning

The orbiter caution and warning (C&W) system and Spacehab subsystems work together to alert

the crew if Spacehab subsystem equipment is failing. When an alarm condition is detected, the orbiter provides a signal that activates the master alarm light in the Spacehab module.

The Spacehab C&W subsystem is defined in three groups:

- Class 1, Emergency C&W
- Class 2, Hardware C&W/software C&W
- Class 3, Fault detection annunciation

Electrical Power Subsystem

The Spacehab electrical power subsystem (EPS) distributes direct current, alternating current, and emergency current sources to subsystems and experiment equipment. Main power is distributed via the power distribution unit (PDU).

The PDU is the major component of the Spacehab EPS. The PDU receives and distributes main dc, secondary dc, and 3-phase 115-volt ac power from the orbiter. Also, the PDU distributes Spacehab inverter-generated, 3-phase 115-volt ac power to subsystem and experiment equipment.

The emergency power received from both the orbiter auxiliary A and aft payload B buses is routed to the Spacehab fire suppression control unit (FSCU) and the monitoring and control panel (MCP).

Control and monitoring of the Spacehab EPS is provided by hardwired interfaces to the SSP, payload multiplexer/demultiplexer (PL MDM), and by discrete inputs and outputs to the DMU.

Environmental Control Subsystem

The Spacehab environmental control subsystem (ECS) controls the habitable environment and provides heat rejection for subsystem and experiment thermal control. The ECS provides this capability during prelaunch, launch, on orbit, entry, and postlanding mission phases. The ECS controls atmospheric temperature control and pressure limitation, contingency depressurization, equipment thermal control, smoke detection, fire suppression, experiment vacuum venting, atmospheric monitoring, trace contaminate removal, and emergency egress breathing capability.

Audio Communication Subsystem

The audio communication subsystem (ACS) provides the Spacehab crew with an audio communication link to the orbiter and to the flight controllers in the Mission Control Center (MCC). The ACS panel, located in the Spacehab module, interfaces with the orbiter's audio central control network (ACCN) to facilitate on-orbit operation. The ACS provides the crew with two independent communication stations located on the ACS panel.

Each communication station has the following audio channels:

- Air-to-ground 1 (A/G1)
- Air-to-ground 2 (A/G2)
- Intercommunication A (ICOM A)
- Intercommunication B (ICOM B)
- Page
- Alarm tone

The channels can be configured independently to talk/listen, listen only, or off.

Fire Suppression Subsystem

The FSS includes both smoke sensors and fire suppression equipment. Detection of fire/

smoke is annunciated through the orbiter C&W electronics unit (CWEU) to crewmembers in both the orbiter and Spacehab module. The fire suppression bottles can be discharged using controls located on the SSP, on the payload safing panel (C3A5), on the Spacehab MCP, or by Spacehab SPEC commanding via the orbiter CRT. Fire suppression firing circuits, smoke detector data circuits, and test/checkout provisions are provided by the FSCU and the MCP.

Activation of the FSS is single fault tolerant during all mission phases. A handheld fire extinguisher is provided for extinguishing localized fires.

Closed Circuit Television Subsystem

The closed circuit television (CCTV) cameras or orbiter-provided camcorders may be located in the Spacehab module for video downlink of Spacehab experiment operations. In the standard configuration, orbiter-provided camcorders are used to provide video recording of Spacehab experiment operations.



Payloads

SPACEHAB Research Double Module (RDM)

SPACEHAB Inc.'s Research Double Module (RDM) is making its first flight on STS-107. The RDM is a pressurized aluminum habitat that is carried in the space shuttle's cargo bay to expand working space aboard the shuttle. The RDM is connected to the shuttle middeck by a pressurized access tunnel. Boeing-Huntsville performed the RDM's systems integration for SPACEHAB and serves as the company's mission integration contractor. SPACEHAB Single Modules outfitted for research or logistics and Double Modules outfitted for logistics have flown on 15 space shuttle missions to date.



The SPACEHAB Research Double Module (RDM) and pressurized access tunnel are lowered toward Columbia's payload bay.

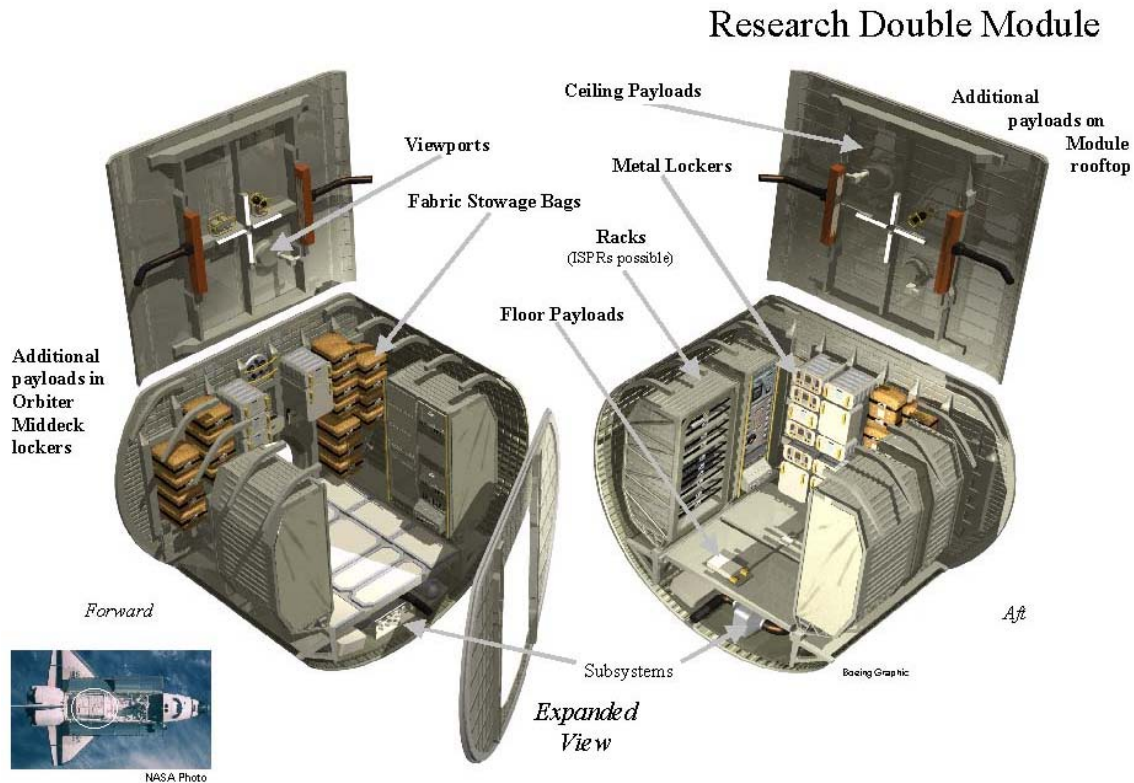

The RDM is approximately 20 feet long, 14 feet wide, and 11 feet high. Outfitted as a state-of-the-art laboratory, it has a pressurized volume of 2,200 cubic feet and can hold up to 61 space shuttle middeck lockers (up to 60 pounds and 2 cubic feet each) plus six Double Racks (1,400 pounds and 45 cubic feet each). The RDM also can accommodate International Space Station Payload Racks (ISPRs). The Module has two viewports and can carry powered rooftop payloads (three on STS-107) using feed-through plates in the module ceiling. The RDM, which has a payload capacity of 9,000 pounds, will carry about 7,500 pounds of research payloads on STS-107. An additional 800 pounds of SPACEHAB-integrated payloads are flying on the shuttle middeck, making a total of 8,300 pounds of research payloads on STS-107.



STS-107 crewmembers check out equipment in the SPACEHAB RDM. Mission Specialist Kalpana Chawla (left) holds a data manual while Mission Specialist David Brown stretches out on the floor to get a closer look during the Crew Equipment Interface Test activities, which include equipment and payload familiarization.

The RDM provides investigators with the latest in telemetry and command control capabilities that are compatible with the International Space Station. The Module provides payload data downlink services via the shuttle's Ku-band communication system, increasing available downlink bandwidth up to 25 Mbps. It is equipped with an enhanced environmental control system designed for a four-person load capability, a key requirement to support round-the-clock crew operations on STS-107.

The Module provides AC and DC power plus air and water cooling for experiments. STS-107 payloads using time-critical components, such as biological samples, require access to the RDM for loading as late as L-31 hours before launch. SPACEHAB will be loading approximately 40 percent of the payloads for STS-107 on the RDM after the Module is installed in the shuttle cargo bay and the shuttle is on the launch pad.



STS-107 Payload Commander Michael Anderson checks equipment during training at SPACEHAB.

SPACEHAB's flight services contract with NASA provides the company with 12 percent of the RDM's payload capacity to sell to commercial customers on STS-107.

SPACEHAB's commercial payloads on the mission include:

- * **Advanced Respiratory Monitoring System (ARMS), European Space Agency:** ARMS is an investigation of pulmonary and cardiovascular changes in humans during rest and exercise in early and later phases of spaceflight. The ARMS facility measures gas compositions during inspiration and expiration of different gas mixtures, heart rate, blood pressure and respiratory rate. STS-107 is the first flight of ARMS. For more information, see the ARMS section in this press kit.
- * **Closed Equilibrated Biological Aquatic System (CEBAS), DLR (German Space Agency):** CEBAS, a middeck payload, is a habitat for aquatic organisms and serves as a facility for conducting microgravity experiments in zoology, botany, developmental biology and ecosystems research. CEBAS flew on STS-89 and STS-90.



- * **Miniature Satellite Threat Reporting System (MSTRS), U.S. Air Force:**
This payload is a communications technology demonstration developed by the Air Force Research Laboratory in Albuquerque, N.M. STS-107 is the first flight of MSTRS.
- * **Commercial Macromolecular Protein Crystal Growth (CMPCG), University of Alabama-Birmingham Center for Biophysical Science and Engineering (UAB CBSE) and SPACEHAB:** CPMG is a commercial facility sponsored by SPACEHAB, which has partnered with UAB CBSE to use the CMPCG facility for the production of large, high-quality protein crystals under controlled conditions in microgravity. Primary customers are the National Space Development Agency of Japan, Canadian Space Agency, and Donald Danforth Plant Science Center.
- * **Combined 2-Phase Loop Experiment (COM2PLEX), European Space Agency:** The COM2PLEX rooftop test facility is designed to investigate the behavior of capillary-pumped loops in microgravity. The facility will demonstrate three different two-phase loops by transporting different amounts of heat from evaporator to condenser and radiating heat into space. STS-107 is the first flight of COM2PLEX.
- * **STARS-Bootes:** For information see the STARS Student Experiments.
- * **STARNAV Star Navigation Experiment, Texas A&M University:**
This experiment, a rooftop payload, is designed to validate a new algorithm for determining precise spacecraft attitude without prior knowledge of position and develop educational interest in space technology and astronomy.
- * **Osteoporosis Experiment in Orbit (OSTEO), Canadian Space Agency:**
OSTEO is an in-vitro evaluation of bone cell activity in microgravity. Baseline bone cell activity and the effects of specific pharmaceutical agents will be assessed. This payload flew on STS-95.
- * **European Research In Space and Terrestrial Osteoporosis (ERISTO), European Space Agency in coordination with the Canadian Space Agency:** ERISTO, an in-vitro evaluation of bone cell activity in microgravity, uses the same facility hardware as the OSTEO experiment. STS-107 is the first flight of ERISTO.



- * **Physiology and Biochemistry 4 (JSC-HLS/PhAB4), NASA Johnson Space Center:** This experiment package includes four life science investigations - Protein Turnover During Spaceflight, Calcium Kinetics During Spaceflight, Renal Stone Risk, and Viral Shedding. Experiment hardware includes blood collection kits; urine collection kits; saliva collection kits; tracer kits; a Portable Clinical Blood Analyzer; an Orbiter Centrifuge; an Enhanced Orbiter Refrigerator/Freezer (EOR/F) that flew on STS-55, STS-58, STS-71, STS-74, STS-84, STS-89, and STS-95; and a Thermoelectric Holding Module (TEHM) that made multiple flights on the space shuttle middeck and is flying for the first time in a SPACEHAB Module on STS-107.

For more information visit:

<http://www.spacehab.com/sts107>



Payload and Payload Integration

Submitted by Group II
 Major General Kenneth W. Hess, Steven B. Wallace, Sally K. Ride, Ph.D.
 1st Lt. Matthew Granger

1.0 BASIC PAYLOAD OVERVIEW

The payload bay configuration for the Space Shuttle *Columbia* (OV-102) for the STS-107 mission, from forward to aft, was the SPACEHAB access tunnel, SPACEHAB Research Double Module (RDM), the Fast Reaction Experiment Enabling Science Technology Applications and Research (FREESTAR) payload, the Orbital Acceleration Research Experiment (OARE), and an Extended Duration Orbiter (EDO) kit to accommodate the extended duration flight needed to conduct all on-board research experiments. Additional individual experiments were loaded into the mid-deck of the Orbiter and on the SPACEHAB RDM rooftop (see Figure 1). Total payload weight for STS-107 was 24,536 pounds.

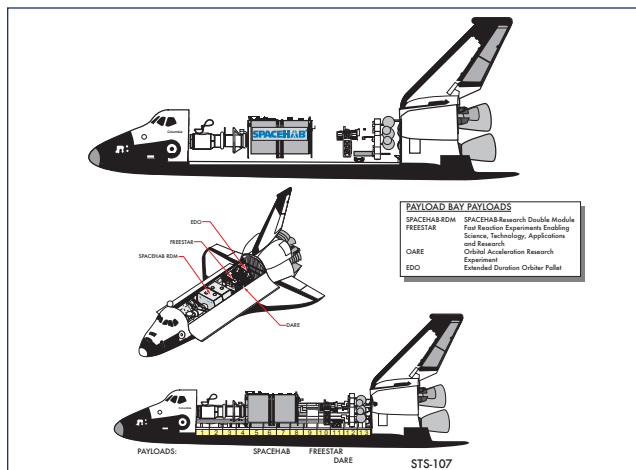

Figure 1. STS-107 Payload bay configuration.

Since STS-107 was a dedicated science research mission, certain payload experiments drove orbital planning requirements. Those requirements were for a 39-degree orbit inclination and a 150 nautical mile altitude, both of which were to support the Miniature Satellite Threat Reporting System

(MSTRS), a U.S. Air Force orbital debris avoidance experiment. The STS-107 mission also required approximately 250 attitude maneuvers while on orbit to satisfy the requirements of FREESTAR and the SPACEHAB rooftop experiment payloads.

1.1 SPACEHAB RDM

Founded in 1984, SPACEHAB Incorporated is a company providing commercial space services to NASA and other organizations. The current bulk of products provided to NASA entail research and logistics modules for integration and use aboard the space shuttle within the payload bay. Since 1993 SPACEHAB has produced four major products for use on the Space Shuttle: the Logistics Single Module (LSM), Research Single Module (RSM), Logistics Double Module (LDM), and most recently, the Research Double Module (RDM). Construction of the first SPACEHAB RDM began on August 1, 1996 and was flown aboard OV-102 on the STS-107 mission. The RDM was developed using a flight-proven single forward module (Flight Unit 1, last flown on STS-95) and an identical aft module (Flight Unit 4, new, per existing design). In addition, knowledge learned from the production of the LDM was applied to the RDM.

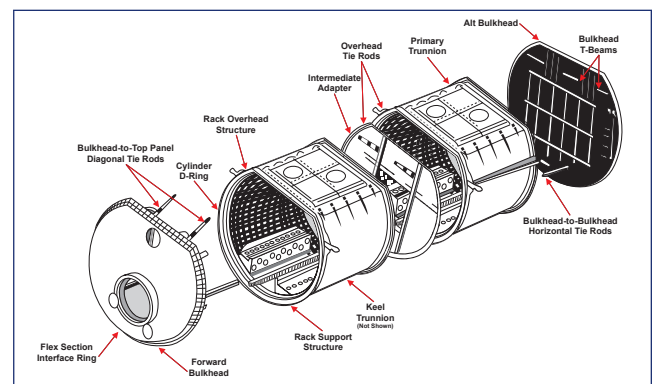

Figure 2. SPACEHAB Research Double Module configuration.

The RDM is a pressurized aluminum research laboratory habitat that connected to the Orbiter via a pressurized access tunnel. It is comprised of two Research Single Modules connected together by an Intermediate Adapter (see Figure 2). It provides a 10,000-pound payload capacity and contains a full array of video, data, command, power, and environment control capabilities. The first flight of a SPACEHAB Research Single Module was in 1993, with the first flight of a Logistics Double Module following in 1996. Below is a list of all SPACEHAB flights:

- STS-57 (RSM) June 1993
- STS-60 (RSM) February 1994
- STS-63 (RSM) February 1995
- STS-76 (RSM) March 1996
- STS-77 (LSM) May 1996
- STS-79 (LDM) September 1996
- STS-81 (LDM) January 1997
- STS-84 (LDM) May 1997
- STS-86 (LDM) September 1997
- STS-89 (LDM) January 1998
- STS-91 (LSM) June 1998
- STS-95 (RSM) October 1998
- STS-96 (LDM) May 1999
- STS-101 (LDM) May 2000
- STS-106 (LDM) September 2000
- STS-107 (RDM) January 2003
- STS-116 (LSM) June 2003*
- STS-118 (LSM) October 2003*

*Planned

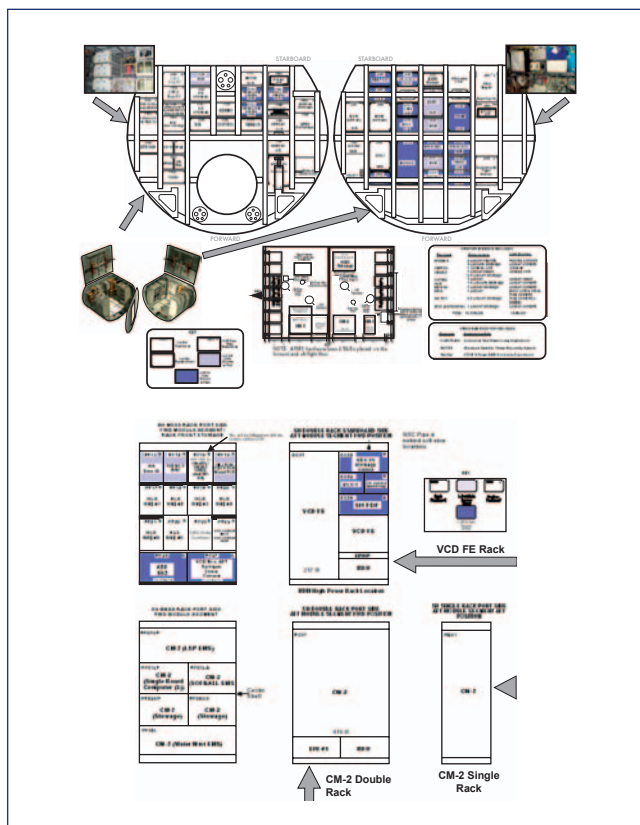

Figure 3. Experiment layout in the SPACEHAB RDM.

The SPACEHAB RDM for STS-107 contained 30 micro-gravity, space, and life science payloads to include commercial, European Space Agency (ESA), and NASA experiments. The following experiment payloads were flown on OV-102 within the RDM for this mission (see Figure 3 for experiment layout within the module):

NASA Office of Biological & Physical Research Payloads (Managed by NASA Code U)

- Combustion Module-2 (CM-2)
 - LSP
 - SOFBALL
 - Water Mist
- Space Acceleration Measurement System Free Flyer (SAMS FF)
- Mechanics of Granular Materials (MGM)
- Ergometer Hardware
- Johnson Space Center Human Life Sciences (JSC HLS)
 - Microbial Physiology Flight Experiments (MPFE)
 - SLEEP-3
 - Automated Microbial System (AMS)
- Astroculture
 - 10/1 (Plant Growth Chamber) (AST-10/1)
 - 10/2 (Glovebox) (AST-10/2)
- Commercial Protein Crystal Growth – Protein Crystallization Facility (CPCG-PCF)
- Commercial ITA Biomedical Experiment (CIBX)
- Fundamental Rodent Experiments Supporting Health-2 (FRESH-2)
- Gravisensing & Response Systems of Plants (BIOTUBE/MFA)
- Biological Research In Canisters (BRIC)

NASA ISS Risk Mitigation Experiment Payloads

- Vapor Compression Distillation Flight Experiment (VCD FE)

NASA/ESA Sponsored Payloads (Managed by NASA & ESA)

- Facility for Adsorption and Surface Tension (FAST)
- Advanced Protein Crystallization Facility (APCF)
- BIOBOX

Commercial Payloads (Managed by SPACEHAB, Inc.)

- Advanced Respiratory Monitoring System (ARMS)
- Miniature Satellite Threat Reporting System (MSTRS)*
- Combined 2 Phase Loop Experiment (COM2PLEX)*
- Space Technology and Research Students (STARS™)
- Star Navigation (StarNav)*
- European Research in Space and Terrestrial Osteoporosis (ERISTO)
- Johnson Space Center Human Life Sciences (JSC HLS)
 - Physiology and Biochemistry 4 (PhAB4)
 - Enhanced Orbiter Refrigerator/Freezer (EOR/F)

- Thermoelectric Holding Module (TEHM)
- Orbiter Centrifuge

Note: The COM2PLEX, StarNav, and MSTRS were located on the rooftop of the SPACEHAB RDM (see Figure 4).

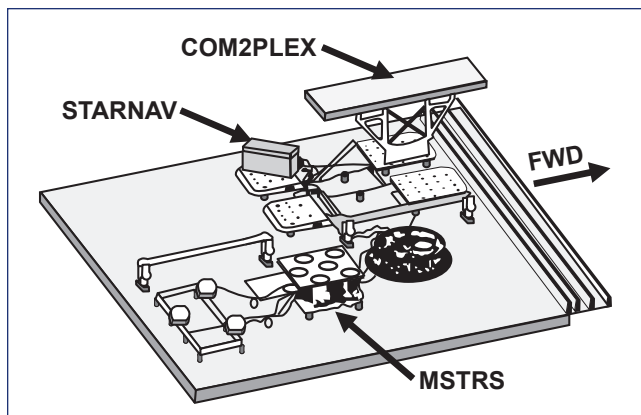

Figure 4. Layout of experiments on the SPACEHAB RDM roof.

Payload experiments for this mission never previously flown included the ARMS, Biopack, BIOTUBE, COM2PLEX, MPFE, MSTRS, StarNav, and VCD FE.

The SPACEHAB RDM required 5500-Watts to power the payload. For ascent/descent, the RDM required 690-Watts DC total and was divided between the module and mid-deck payloads. Main power for the RDM is supplied from the Orbiter by way of two main access cables, entering the module through the forward bulkhead. The power integration between SPACEHAB and OV-102 required the following specific electrical hardware:

- 4 power outlets in order to support 5 powered payloads on ascent
- 7 power outlets in order to support 5 powered payloads on orbit
- 4 power outlets in order to support 4 powered payloads on descent

The environmental control for SPACEHAB required 590 Watts of power for ascent/entry and was designed to provide continuous moisture and atmospheric control and monitoring for three crewmembers, and up to six members for short durations. It was also designed to maintain the SPACEHAB RDM temperature between 65 and 80 degrees Fahrenheit through the use of both air and water-cooling loops, and provide adequate carbon dioxide removal as well. New to the RDM design was the addition of a moisture removal system for added capability to accommodate larger moisture generation rates (i.e. the addition of a human performance ergometer bicycle experiment) and to aid in the overall heat rejection capability (i.e. to accommodate the CM-2 experiment).

A complete fire suppression system was incorporated into the SPACEHAB RDM. Smoke detectors identical to those used aboard the Orbiter provided detection capabilities, and ten Halon bottles built into the module provided the means

for fire suppression. A full depressurization capability also existed, enabling the crew to vent the module and remove all oxygen (one of the three requirements for fire to exist). The module also contained emergency breathing systems for up to two crewmembers.

Data and command systems within the RDM included the new Experiment Data System (EDS) to support experiment requirements. Also, a complete RDM display feature is also available to the flight deck crew if needed in order to monitor module readings and warnings via the main flight deck console screens.

When compared to previously flown single and double modules, the RDM contained the following newly developed, first-time use systems, modified systems, and series items:

- Aft Module Segment (FU-4)
- Aft Module Rack Support Structure (RSS) and Overhead Attachment
- Aft Module Floor
- Aft Module Subfloor
- Hab Fan Assembly*
- Air Balancing Box*
- Air By-Pass Valve Assembly*
- Air Mixing Box
- Atmospheric Revitalization System (ARS) Fan Package/Inlet Muffler
- Condensing Heat Exchanger (CHX)*
- Water Separator Assembly (WSA)*
- Condensate Storage System (CSS)*
- CO₂ Control Assembly (CCA)*
- Environmental Control Unit (ECU)
- Centralized Experiment Water Loop (CEWL)*
- Centralized Experiment Rack Suction Cooling
- Aft Power Distribution Unit (APDU)*
- Aft DC-AC Power Inverters*
- Rack Distribution Unit (RDU)
- Emergency Power Distribution Box (EPDB)
- Luminary Switch Box
- Aft Module Luminaries
- EDS Main Unit (EDSMU)
- EDS HUB
- EDS Experiment Interface Unit (EIU)
- EDS Onboard Crew Station (available when required)

* Indicates new hardware added in the aft module subfloor

The SPACEHAB RDM incorporated no jettison pyrotechnics and, once loaded for launch, weighed 20,249 pounds (this represents both the minimum descent and maximum ascent weight).

1.2 FREESTAR

The Fast Reaction Experiment Enabling Science Technology Applications and Research (FREESTAR) is a Hitchhiker payload managed and operated by Goddard Space Flight Center as part of the Shuttle Small Payloads Project. The FREESTAR payload contained no radioactive or ionizing radiation sources and demonstrated no operational function capability, such as rocket motor firings, appendage deploy-

ments, or separations. FREESTAR weighed 4,427 pounds (FREESTAR and carrier combined) once fully loaded with experiments and, for the STS-107 mission, was mounted on a crossbay Multipurpose Equipment Support Structure and included six Earth science and microgravity experiments as listed below (see Figure 5 for experiment layout):

- Mediterranean Israeli Dust Experiment (MEIDEX)
- Shuttle Ozone Limb Sounding Experiment-2 (SOLSE-2)
- Critical Viscosity of Xenon-2 (CVX-2)
- Solar Constant Experiment-3 (SOLCON-3)
- Space Experiment Module (SEM)
- Low Power Transceiver (LPT)

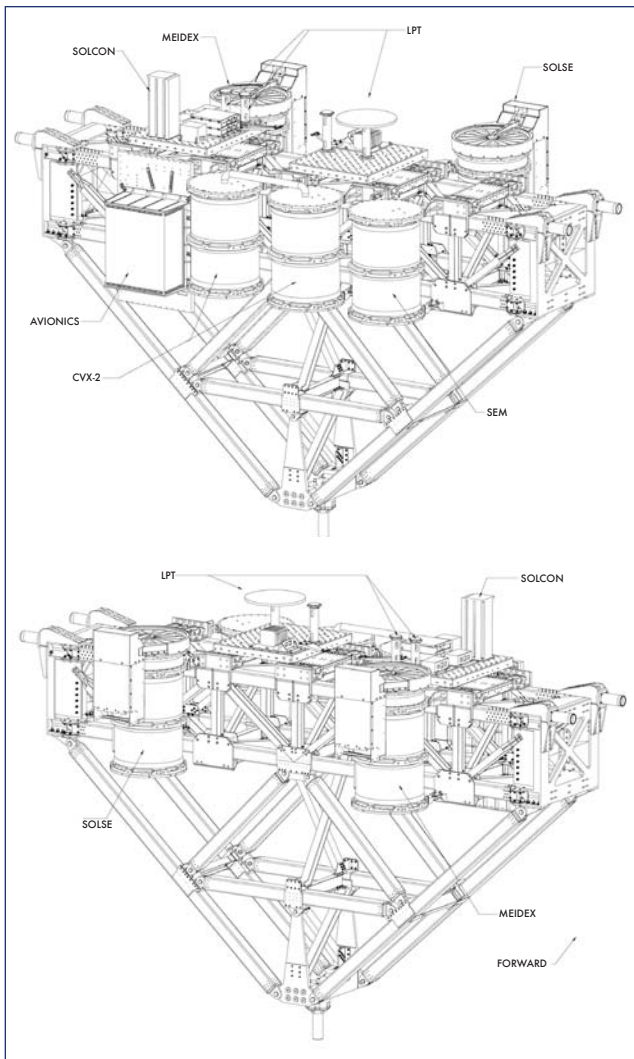

Figure 5. FREESTAR experiment configuration.

1.3 MID-DECK

The mid-deck payloads consisted of experiments housed in the forward bulkhead of the Orbiter mid-deck and were controlled and monitored by SPACEHAB, Inc. The following specific experiments were flown on the mid-deck of OV-102 for STS-107 (see Figure 6 for experiment layout):

- Biopack
- Biopack w/ Passive Thermal Controlled Units (PTCUs)
- Closed Equilibrated Biological Aquatic System (CEBAS)
- Ziolite Crystal Growth-1 (ZCG-1)
- Osteoporosis Experiment in Orbit (OSTEO)
- Bioreactor Demonstration System-05 (BDS-05)
- Biological Research In Canisters (BRIC)
- Commercial Macromolecular Protein Crystal Growth (CMPCG)

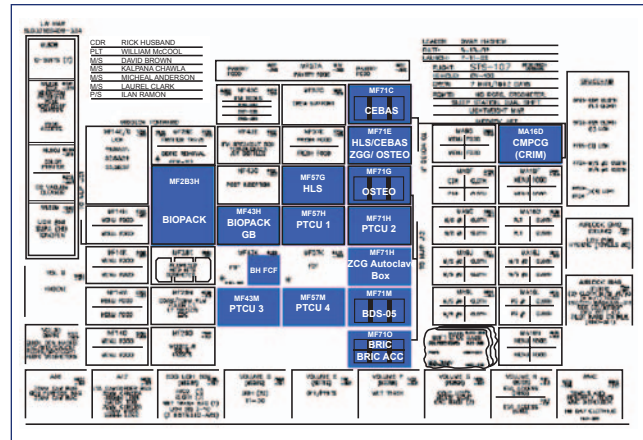

Figure 6. Mid-deck experiment layout.

2.0 PAYLOAD INTEGRATION

2.1 READINESS REVIEWS

The original launch date for STS-107 was January 11, 2001. Based on adjustments to estimated rollout dates, the launch was rescheduled for February 22, 2001. In order to support this new launch date, a Cargo Integration Review (CIR) was scheduled for February 22, 2001. The *Triana* payload, designed to observe and study Earth and space-based phenomenon, was originally scheduled to fly aboard OV-102 for the STS-107 mission, along with the SPACEHAB RDM. Command and data inputs (Triana Annex 4) were late for the CIR and forced a one-month launch slip to March 22, 2001. Because of this launch delay and other factors, it was decided to remove the *Triana* payload from the flight manifest for STS-107 and exchange it with the FREESTAR payload. This change-out required an additional launch slip to June 14, 2001. The SPACEHAB RDM then required a Ku-band verification test that required 6 weeks to accomplish and delayed the launch date to August 2, 2001. Other shuttle processing delays, engine flowliner crack repairs, and lower priority of STS-107 behind STS-109, 112, and 113 due in part to space station construction timelines forced several additional launch slips for STS-107 until the final launch date of January 16, 2003 was finalized and executed.

2.1.1 Payload Readiness Review

The initial Payload Readiness Review (PRR) was conducted on May 9, 2002. The purpose of the PRR was to review the

processing of the SPACEHAB RDM and FREESTAR payloads conducted at Kennedy Space Center, ensure readiness for installation of the payloads into the OV-102, and ensure the Orbiter and Ground Support Equipment systems were ready to receive the payloads. OV-102 processing at the Orbiter Processing Facility (OPF) was planned to take place in High Bay 3.

There were no anomalies reported during the PRR by any payload representative, and only one special topic was brought forward. During ground processing, a “ding” was found on the inside wall of the SPACEHAB RDM. Based on results from the inspection and non-destructive analysis, it was deemed non-detrimental to the structural integrity of the RDM and was repaired. The Payload Safety Review Panel (PSRP) closed the topic on April 15, 2002.

All payloads were planned to be integrated together horizontally at the Space Station Processing Facility (SSPF), then loaded horizontally into the Orbiter at the Orbiter Processing Facility (OPF), with several individual time-critical experiments to be installed as part of a late vertical stow on Launch Complex 39A. SPACEHAB Inc. would be responsible for all late stow deliveries to the pad, at which time the individual experiment payloads would be turned over to the Flight Crew Equipment (FCE) team for loading. Ten mission success Launch Commit Criteria (LCC) and three Payload Safety LCCs were identified and approved for this payload (see Figure 4).

As briefed in the engineering status section of the PRR, all Section 20 non-compliances were known to the test team, were generic to SPACEHAB and FREESTAR, and were built into the forward planning. There were no mission specific Interface Control Document (ICD) waivers, deviations, or exceedances identified for this mission. There were also no unexplained anomalies present.

Primary payload software used for this RDM mission was Version 38.01, the Back-up Flight Software (Ascent) was Version 38.24.B.10, and there were no issues or concerns surrounding these software packages. There were also no issues or concerns regarding ground or Orbiter software.

Specifically regarding the SPACEHAB RDM, which was the primary payload for STS-107, there were no open anomalies. This was the first flight of the RDM, but was developed from “flight proven” Research Single Module (RSM) and Logistics Double Module (LDM) designs. The tunnel connecting the SPACEHAB RDM to the Orbiter airlock was developed from previous tunnel designs and all interfaces were similar to previous configurations. The RDM/Orbiter interfaces were identical to the RSM and LDM designs, and changes were minimized to include only those required for payload performance. Changes to the standard SPACEHAB module interfaces are listed below:

- Two Additional DC Power Feeds (4 total – only 3 used for STS-107)
- Additional AC (AC2) Power Feed
- KU-Band Signal Processor (KUSP) Interfaces (channels 2 and 3 for downlink, forward link for commanding)

2.1.1 Pre-Flight Readiness Review

The initial STS-107 Pre-Flight Readiness Review occurred on June 20, 2002, and after a launch slip, the delta review took place on December 11, 2002. Payload processing was reported as complete, except for late stowage of experiments, which was planned to occur at the launch pad prior to launch. No operations requiring payload door opening on the pad were planned in order to complete the late stowage activities, and all integration compatibility requirements were met, all without issue or constraints. The acoustics and hardware branches also reported no outstanding concerns and no constraints to flight.

2.1.2 Flight Readiness Review

The STS-107 Flight Readiness Review occurred on January 9, 2003. An overview of the payload to be flown on this mission was given, as well as key mission considerations, such as time on orbit, altitude, and launch scrub turnaround timelines. It was noted STS-107 was the first Extended Duration Orbiter (EDO) mission since STS-90 in April 1998, and the late addition of six passive sample canisters to the BRIC mid-deck locker was discussed as well. The late addition of the six canisters was approved at the January 8 Payload Safety Review Panel (PSRP).

The Integrated Experiment Hazards Assessment was briefed as complete, all toxicology processes were complete, there were no outstanding Non-Compliance Reports, and the PSRP was complete. There were no payload constraints to launch and all reviews were complete.

2.2 SAFETY REVIEWS

2.2.1 Integrated Safety Assessments

The SPACEHAB RDM Phase III Flight Safety Review took place in July 2000, with Boeing/SPACEHAB Inc. presenting information. According to the safety data package, the structural verification of the RDM was accomplished by the maximum use of previously proven hardware, similarity in design to previous modules, and the use of verification tools such as design coupled load analysis, stress analysis and fracture control, and design variation sensitivity analysis.

For the STS-107 mission, there were 14 SPACEHAB RDM Flight Hazard Reports written. Previous Space Shuttle mission hazard reports were reviewed and assessed for applicability to the specifics of the STS-107 mission, and the 14 hazard reports written for the RDM were in addition to previously submitted reports. This mission was the sixth flight for the forward module, FU-1, and fatigue effects were included in the final safety analysis. The module was most recently flown aboard STS-95. The Intermediate Adapter and aft module (FU-4) were new-builds per existing designs. At the conclusion of the SPACEHAB Fracture Control Board, conducted with Boeing, all margins of safety were positive for the primary and secondary structures and all hardware met the 10-mission minimum design life requirements. All subsystems were rated with a design life greater than 50 missions. An RDM Flammability Analysis was also conducted.

The SPACEHAB RDM pressurized environment is identical to the Orbiter environment.

The FREESTAR Phase III Flight Safety Data Package was presented in February 2002 at Goddard Space Flight Center. The FREESTAR payload contained no radioactive or ionizing radiation sources and the Hitchhiker carrier hardware supporting FREESTAR had never experienced any major anomalies or structural failures supporting previous flights. The structural verification plan verified FREESTAR to survive an 11g force about the X, Y, and Z-axis and, for this mission, did not have any operational function capability, such as rocket motor firings, appendage deployments, or separations. There were also no significant heat generation or electromagnetic field sources associated with the payload. It was ultimately determined FREESTAR introduced no additional hazards as a result of integration with the rest of the STS-107 payload or OV-102 and met all payload safety requirements.

2.2.2 Payload Readiness Review

At the Payload Readiness Review (PRR) on May 9, 2002, the Safety and Mission Assurance (S&MA) Division reported all generic payload hazards were properly controlled and there were no unique hazards identified. There were no open ground safety action items, but one “mishap” had occurred during ground processing. A worker was exposed to chemicals during the BRIC-14 processing in Hanger L, but was released back to regular duty soon after. All mission status recommendations from the safety side of the PRR were positive and indicated a readiness for integrated ground operations.

2.2.3 Pre-Flight Readiness Review

During the December 11 Pre-Flight Readiness Review, all payload cargo physical stresses on the Orbiter were reported as within acceptable limits with positive margins of safety. From the Cargo Safety division, the final STS-107 Cargo Integrated Risk Assessment Report was reported as complete and delivered on May 31, 2002, with closure of all tracking log items set for the next day, December 12, 2002. The Payload Environmental Assessment Report was also reported as submitted, as of May 29, with no issues or concerns identified, and the Safety Critical Pin-to-Pin Assessment was reported as completed on the same day. Cargo Safety also reported any open In-Flight Anomalies (IFA) and/or IFA actions from previous flights contained no payload safety concerns specific to the STS-107 mission. Payload Safety reported all safety hazard reports had been approved, all open work remaining was defined and approved, there were no Non-Compliance Reports, and the safety certification process was complete.

2.2.4 Payload Safety Review Panel

The final Payload Safety Review Panel (PSRP) meeting prior to the STS-107 mission was completed on January 8, 2003 where, among other items, the Integrated Safety Assessments conducted for the SPACEHAB RDM and FREESTAR payloads were presented for final approval at Kennedy Space Center. Also presented at the PSRP were the

results of the Ground Safety Review Panel and the Flight Safety Review Panel for PSRP approval.

One thing addressed at the PSRP was the issue of hazardous materials. It was reported there were only very limited amounts of hazardous materials within the payload of STS-107. Only negligible amounts of radiological material (i.e. Americium-241 in smoke detectors, the same as in the Orbiter) were on board STS-107 and posed no health hazard. The following material descriptions are for any materials planned to be on board the OV-102 at or above a Toxic Hazard Level 2:

2.3 PRE-LAUNCH PREPARATION

The EDO kit was loaded into aft section of the Orbiter’s payload bay in OPF-3, on April 25, 2002. The SPACEHAB RDM/FREESTAR payload was also loaded horizontally into the Orbiter’s payload bay on March 24, 2002 with the Integration Verification Test occurring on June 6. The payload bay doors were closed for flight in the OPF for the last time on October 31 and were not opened prior to launch (all late stow activities were accomplished via the mid-deck and RDM access tunnel). OV-102 rollover from the OPF to the Vehicle Assembly Building (VAB) for external tank and solid rocket booster mating occurred on November 18, 2002. Mating occurred on November 20, and vehicle rollout to Launch Complex 39A occurred without incident from a payload perspective on December 9.

The launch team was exercised in the protocol and flow of the payload LCC through a full Cargo Integration Test Equipment (CITE) simulation performed on December 5, 2002. In the event any payload LCC were violated during the launch count, and required a hold, Kennedy Space Center personnel were responsible for calling the hold from data gathered by the Ground Launch Sequencer (GLS).

Experiment	Hardware/ Hazard	Amount	Hazard Level	Notes
ARMS	CO ₂ Absorber	20g X 2	2	2 units in storage @ launch - 1 will be mounted on ARMS module #2 on orbit
CM-2	Exhaust vent package - gas filter/LiOH, Silica	590g, 565g	2	None

During the Flight Readiness Review (FRR), all SPACEHAB RDM powered health checks were reported as complete with no anomalies or outstanding issues.

SPACEHAB was ultimately powered up at L-51 hours (January 14, 2003) in order to prepare for the late stowage of time critical experiments. Module Vertical Access op-

erations for SPACEHAB took place at L-46 hours and were completed by L-31 hours without incident. Late mid-deck payload stowage occurred at the launch pad as well. Flight crew equipment loading took place at L-22:30 hours, while mid-deck experiment loading took place from L-19 to L-16 hours. Fourteen experiments were loaded, four of which were powered, all without incident. No LCCs were violated prior to launch at T-0.

3.0 MISSION OVERVIEW

3.1 LAUNCH

STS-107 performed a successful morning launch from Kennedy Space Center, Launch Complex 39A, on January 16, 2003 at 9:39 a.m. CST, early in the 2.5 hour launch window. The planned orbit inclination was at 39 degrees to the equator and at an altitude of 150 nautical miles. The general mission overview consisted of a dedicated science and research flight lasting 16 days (plus 2 weather extension days if needed) with a crew of seven. Due to the extensive amount of research conducted on this mission (SPACEHAB alone required 468 hours of on-orbit crew time), the crew conducted dual shift operations in order to maintain 24 hour a day operations. Crewmembers were divided into two teams and assigned alternating 12-hour shifts. The “Red Team” consisted of Husband, Chawla, Clark and Ramon. The “Blue Team” consisted of McCool, Brown and Anderson.

The following SPACEHAB RDM experiments were powered for the ascent phase of the mission: Advanced Protein Crystallization Facility (APCF), Astroculture, Bioreactor Demonstration System-05 (BDS-05), BIOBOX, Commercial ITA Biomedical Experiment (CIBX), CPCG-PCF, European Research in Space and Terrestrial Osteoporosis (ERISTO), Fundamental Rodent Experiments Supporting Health-2 (FRESH-02), Space Technology and Research Students (STARS-Bootes), Thermoelectric Holding Module (TEHM).

The following mid-deck experiments were powered for the ascent phase of the mission: Biological Research In Canisters (BRIC), Closed Equilibrated Biological Aquatic System (CEBAS), Commercial Macromolecular Protein Crystal Growth (CMPCG), and Osteoporosis Experiment in Orbit (OSTEO).

FREESTAR was not powered during the ascent phase of the mission.

From downlinked data received by Mission Control and the Payload Operations Control Center (POCC), all payload telemetry was nominal during the launch phase.

3.2 ON-ORBIT

At 11:35 a.m. CST, after orbital insertion, the payload bay doors were opened and the go-ahead was given to begin on-orbit operations. The Blue Team began their first sleep cycle while the Red Team began their first shift of on-orbit payload operations. The SPACEHAB RDM was powered during launch to ensure cooling of all experiments on board and, as

their first order of business, the crew successfully activated the RDM and all associated scientific experiments. All on-orbit equipment required for the mission was also unstowed.

On the ground, the first Mission Management Team (MMT) meeting occurred on Friday, January 17, 2003 (for more in-depth descriptions of anomalies listed, see Section 4.2). A SPACEHAB Ku-band Channel 2 anomaly was discussed and a ground systems problem was suspected. Channel 3 data was working nominally and it was determined MOD resources would be made available if needed. The current cryo margin was briefed as 22 hours past nominal end-of-mission due to lower than predicted payload and SPACEHAB RDM power use. A failure of the RDM ICOM B transmission link was also discussed and ICOM A was being used without incident.

The second MMT occurred on Tuesday, January 21, 2003. A SPACEHAB RDM Water Separator Assembly (WSA) leak under the aft sub-floor was discussed in-depth, along with the ensuing electrical short and shutdown of both rotary separators. The possibility of re-starting one of the rotary separators after drying and unclogging was brought forward. An In-Flight Maintenance (IFM) procedure to re-route cooling ducting was discussed and it was determined no new IFM would be carried out without prior approval of the MMT since an electrical short had been confirmed, even if that meant convening a special MMT. A 70mm Hasselblad hand-held camera problem, MSTRS experiment telemetry and command anomalies, and the continuing KU anomaly were also discussed.

The third MMT occurred on Friday, January 24, 2003. The main payload-related topic discussed was the RDM water leak anomaly and IFM development. RDM internal temperature had peaked at 81 degrees Fahrenheit, one degree above maximum allowable (medical was aware of it and it was deemed acceptable). Airflow adjustments were made and the temperature changes were sufficiently moderated so there was no need to implement the cooling duct re-routing IFM. Instead, a plan is in work to use the DC vacuum to clean up any excessive water under the sub-floor prior to entry.

The fourth MMT occurred on Monday, January 27, 2003. Since adjustments to the air flow from the Orbiter was maintaining sufficient cooling in the SPACEHAB RDM, it was re-stated no further IFM to fix the original RDM problem would be needed. It was also recommended the IFM developed to inspect under the sub-floor prior to entry should be implemented.

The fifth, and final, MMT occurred on Thursday, January 30, 2003. The IFM plan to inspect under the sub-floor of the SPACEHAB RDM was planned for later in the day, as well as a plan to vacuum any residual water with the Orbiter DC vacuum cleaner. It was reported that the crew, during all subsequent inspections since the initial water clean up, still had not observed any visible water remaining. A Combustion Module activation problem was briefed and reported as successfully resolved.

The crew aboard *Columbia* conducted on-orbit research

experiments throughout their 16 days on orbit, completing a total of 255 orbits prior to the de-orbit burn. In preparation for the descent phase of the mission, crewmembers began deactivating experiments and stowing gear on January 31, 2003. One of the Orbiter's three auxiliary power units was activated to perform routine flight control surface checks and the reaction control system jets were also simultaneously test-fired in preparation for re-entry.

A complete accounting of all on-orbit payload-related anomalies is provided in Section 4.2 of this report.

3.3 REENTRY

The SPACEHAB RDM was deactivated on the evening of January 31 and was closed for the final time on the morning of February 1. The deorbit burn was performed at 7:15 a.m. CST, February 1, with a scheduled landing time at Kennedy Space Center of 8:16 a.m. CST.

The following SPACEHAB RDM experiments were powered for the descent phase of the mission: Advanced Protein Crystallization Facility (APCF), Astroculture, Bioreactor Demonstration System-05 (BDS-05), BIOBOX, Commercial ITA Biomedical Experiment (CIBX), CPCG-PCF, Enhanced Orbiter Refrigerator/Freezer (EOR/F), Fundamental Rodent Experiments Supporting Health-2 (FRESH-02), Space Technology and Research Students (STARS-Bootes), Thermoelectric Holding Module (TEHM).

The following mid-deck experiments were powered for the descent phase of the mission: BIOPACK, Closed Equilibrated Biological Aquatic System (CEBAS), Commercial Macromolecular Protein Crystal Growth (CMPCG).

FREESTAR was not powered during the descent phase of the mission.

From de-orbit burn through Orbiter Loss of Signal (LOS), all payload telemetry data received by ground control was nominal according to Payload Multi-Purpose Support Room logs, the POCC, and customer downlinks. In addition, the crew did not report any payload-related issues during the entry phase of the mission. Specifically, the following SPACEHAB RDM data telemetry was reviewed, all of which was nominal through LOS:

- Module Pressure
 - Total pressure
 - Partial pressure O₂
- Cooling Loop Parameters
- Module / Orbiter Interface
 - Coolant lines
 - Power
 - Data
 - Electrical current
- CG Parameters

All OARE downlinked telemetry data was nominal through LOS and the attachment base plate was recovered from the wreckage, with all structural fasteners still attached. FREESTAR was powered off for the descent phase of the mission.

4.0 ANOMALIES

4.1 LAUNCH

There were no anomalies detected regarding the payload or cargo bay by the STS-107 crew or mission control in Houston during launch (from T-0 through MECO).

4.2 ON-ORBIT

The following is a listing of all on-orbit payload systems anomalies, a brief description of the impact to the mission, corrective actions taken, and effects of the anomaly on the payload and mission (from MECO through de-orbit burn).

1. No ICOM B Transmission In SPACEHAB (PLD-001)

During communication checks between the Orbiter and SPACEHAB on January 17, the crew reported transmissions on ICOM B were not being heard in the RDM. There was no impact to the mission due to other redundant means of communication, such as the use of ICOM A. The problem was traced to an audio switch configuration and full communication was restored.

2. SPACEHAB Water Loop Degradation (PLD-002)

Payload Heat Exchanger, Subsystem Water Pump outlet pressure, and Total Flow rates for the SPACEHAB water loop were observed steadily decreasing, indicating a pump filter blockage or pump degradation. The impact of this would be the inability for SPACEHAB to maintain the required water loop temperature to provide cooling for the operation of several payloads. Pump 2 was allowed to run as long as possible to catch any additional filter debris and was turned off. Pump 1, the backup pump, was subsequently activated for use for the rest of the mission.

3. MEIDEX Telemetry Corruption (PLD-003)

On January 18, corrupt telemetry was occasionally appearing in the Hitchhiker data stream. This corrupt data provided inaccurate MEIDEX health and status parameters. Ground payload controllers performed software patches to their ground unit, which was thought to be the source of the problem, and the system worked accurately thereafter.

4. MEIDEX VCR Anomaly (PLD-004)

MEIDEX VCRs 2 and 3 stopped recording immediately after the activation command was given by ground control. As a result, there was no VCR recording of orbit #28, but the VCRs were successfully activated during orbit #29. The problem was traced to the previous MEIDEX telemetry anomaly.

5. KU Channel 2 Data Dropouts (PLD-005)

Hardware "lock-ups" were occurring within SPACEHAB since the first flight day. The problem was traced to errors received by the Payload Operations Control Center (POCC). The ability to monitor real-time Ku-band Channel 2 data was lost for a few minutes. The crew performed some troubleshooting to try to solve

the anomaly, but did not solve the anomaly and no further troubleshooting was planned for the flight (ground troubleshooting would continue)

6. **BDS-05 Incubator Temperature High (PLD-006)**
A crewmember observed the BDS-05 incubator temperature was high on the third flight day. Too high of a temperature would result in the loss of the science for that specific experiment. It was found the internal fans stopped running and the crew, with assistance from ground control, reset the payload and the temperature returned to the designed parameters.
7. **RS1 Potentially Failed Due To Flooding (PLD-007)**
After noticing a constant reading from the Condensate Tank Pressure on Flight Day 4, the crew checked under the SPACEHAB AD-05 subfloor panel to check for the presence of water. The crew reported seeing over 2 quarts of water around the Water Separator Assembly (WSA), water soaked acoustic pads, and water covering the Aft Power Distribution Unit. The crew used towels to soak up the water and Rotary Separator (RS) #1 was turned off for the remainder of the flight, while RS2 was powered on to compensate. The crew also changed control of the Air Bypass Valve to “Bypass Override” so ground could take control the bypass valve. Blockage internal to RS1 was thought to have caused the flooding under the aft subfloor. A more detailed analysis to determine what happened was planned for post-flight.
8. **MPFE Card Tray #6 Jam (PLD-008)**
Card tray #6 experienced a “motor time out jam” on January 22, creating the potential for other card jams on other trays. The jam was isolated by the crew to tray #6. For the remainder of the mission, further cards were placed in the Flight Checkout card tray to avoid jams.
9. **SH RS2 Failure (PLD-009)**
On January 20, an electric short to RS2 was detected and alarmed in SPACEHAB. The POCC commanded the RS2 off and inspection of the circuit breakers by the crew confirmed the short. With both Rotary Separators turned off, SPACEHAB lost all condensation collection capability and required the Orbiter to control humidity. To mitigate condensation in the RDM, the SPACEHAB water loop temperature was raised above the RDM dew point and ground control began controlling the bypass valve to regulate the SPACEHAB temperature. In order to maintain the temperature within acceptable margins, the Orbiter water loops were adjusted and heat loads were reduced. Prior to entry, the WSA under the SPACEHAB subfloor was visually inspected by the crew for water and none was reported. All holes in the WSA were covered with tape to keep any remaining water from escaping during entry.
10. **BIOPACK Premature Shut Down (PLD-010)**
The BIOPACK payload shut down on four separate

occasions, twice when the freezer door was opened, twice when it was not. The loss of the cooler/freezer feature would result in the loss of two experiments. The crew re-cycled the power for BIOPACK but the problem persisted. The affected experiments were transferred to the PTCU 1 payload for the remainder of the mission.

11. **CM-2 / MIST Flame Tube Evacuation Leak (PLD-011)**

On January 28, gas from the Combustion Module chamber was leaking into the evacuated MIST flame tube. The crew was unable to start the Water Mist Fire Suppression Experiment. In flight maintenance was performed to seal off the gas sampling line and the crew successfully fixed the leak. The repair delayed the start of the Water Mist Fire Suppression Experiment, but had no other adverse affects and the 34 planned runs of the experiment were still accomplished prior to the end of the flight.

4.2.1 SPACEHAB Condenser Anomaly Description

On January 20, one of two SPACEHAB RDM Rotary Separators failed. These systems are designed to collect and distribute water produced by normal condensation buildup during operation of the cooling system. Rotary Separator #1 (RS1), located under the aft subfloor of the SPACEHAB RDM, began leaking, most likely due to an internal blockage, and was shut down. The exact amount of water released was unknown but estimates ranged from between one cup of water to two liters. Upon inspection under the subfloor, water was observed surrounding the Water Separator Assembly (WSA), soaking into acoustic pads, and covering the Aft Power Distribution Unit. The crew used towels to soak up the water and changed the Air Bypass Valve (ABV) configuration to “Bypass Override”, allowing ground control to operate the valve. The secondary system, Rotary Separator #2 (RS2), was turned on and operated normally, adequately compensating for the primary system.

Several hours later on January 20, RS2 experienced an electrical short, most likely due to water from the RS1 leak coming in contact with the electrical connections of RS2. Onboard alarms “223 SH INV AFT PB A” and “225 SH RS2 SPD LO” annunciated, while ground control simultaneously observed an electrical spike via fuel cell and SPACEHAB telemetry (the spike returned to normal shortly after). The crew inspected the circuit breakers on board and verified two of the three related breakers (CB 8 Phase B & C that powered the WSA) were tripped. The crew, at the instruction of ground control, then manually tripped the third circuit breaker (CB 8 Phase A). The POCC commanded the RS2 off, at which time all loads returned to normal.

The shutdown of both Rotary Separators resulted in the loss of the SPACEHAB RDM’s ability to collect condensation water and required the Orbiter systems to control humidity within the RDM.

In order to reduce the likelihood of additional condensation within the RDM, the module’s water loop temperature

was increased to bring it above the dew point. This raise in water loop temperature would allow operations within the SPACEHAB RDM to continue without the risk of additional condensation. The previous ABV reconfiguration was determined as sufficient to control heating within the RDM, and an additional plan to re-route air ducts from the Orbiter to the module to increase air flow was deemed not necessary. Additional adjustments to the Orbiter water loop, and reductions in the heat load within the SPACEHAB RDM, were sufficient to maintain an acceptable air temperature range of around 73 degrees Fahrenheit (after an initial climb in temperature to 80 degrees).

In preparation for the de-orbit burn and entry, the crew visually inspected under the subfloor of the SPACEHAB RDM one last time to ensure no water was present on January 30. No moisture was found. The crew covered several holes in the WSA with tape as a precaution to ensure any water present, but not visible, did not escape during entry. Since an electrical short occurred earlier in the mission, ground controllers associated with the EGIL console instructed the Orbiters AC power bus to be turned off for entry to prevent a short from propagating to the Orbiter's main power supply, in the event another RDM electrical short occurred.

The SPACEHAB RDM was deactivated as planned on January 31 in preparation for entry and closed for the last time early on the morning of February 1.

4.3 REENTRY

There were no anomalies detected regarding the payload or cargo bay by the STS-107 crew or the Mission Control Center in Houston during entry (from de-orbit burn through LOS).

APPENDIX A: ACRONYMS

ABV	Air Bypass Valve	MGM	Mechanics of Granular Materials
AMS	Automated Microbial System	MPFE	Microbial Physiology Flight Experiments
APCF	Advanced Protein Crystallization Facility	MMT	Mission Management Team
APDU	Aft Power Distribution Unit	MSTRS	Miniature Satellite Threat Reporting System
ARMS	Advanced Respiratory Monitoring System	NASA	National Aeronautics and Space Administration
ARS	Atmospheric Revitalization System	OARE	Orbital Acceleration Research Experiment
BDS-05	Bioreactor Demonstration System-05	OPF	Orbiter Processing Facility
BIOTUBE/MFA	Gravisensing & Response Systems of Plants	OSTEO	Osteoporosis Experiment in Orbit
BRIC	Biological Research In Canisters	OV	Orbiter Vehicle
CCA	CO2 Control Assembly	PhAB4	Physiology and Biochemistry 4
CEBAS	Closed Equilibrated Biological Aquatic System	POCC	Payload Operations Control Center
CEWL	Centralized Experiment Water Loop	PRR	Payload Readiness Review
CG	Center of Gravity	PSRP	Payload Safety Review Panel
CHX	Condensing Heat Exchanger	PTCU	Biopack w/ Passive Thermal Controlled Unit
CIBX	Commercial ITA Biomedical Experiment	RDM	Research Double Module
CIR	Cargo Integration Review	RDU	Rack Distribution Unit
CITE	Cargo Integration Test Equipment	RS	Rotary Separator
CM-2	Combustion Module-2	RSM	Research Single Module
CMPCG	Commercial Macromolecular Protein Crystal Growth	RSS	Rack Support Structure
COM2PLEX	Combined 2 Phase Loop Experiment	S&MA	Safety and Mission Assurance
CPCG-PCF	Commercial Protein Crystal Growth – Protein Crystallization Facility	SAMS FF	Space Acceleration Measurement System Free Flyer
CSS	Condensate Storage System	SOFBALL	Structure of Flameballs at Low Lewis Numbers
CVX-2	Critical Viscosity of Xenon-2	SEM	Space Experiment Module
DC	Direct Current	SOLCON-3	Solar Constant Experiment-3
ECU	Environmental Control Unit	SOLSE-2	Shuttle Ozone Limb Sounding Experiment-2
EDO	Extended Duration Orbiter	SSPF	Space Station Processing Facility
EDS	Experiment Data System	STARSTM	Space Technology and Research Students
EDSMU	Experiment Data System Main Unit	STS	Space Transportation System
EGIL	Electrical Generation and Integrated Lighting	T•	Time minus (minutes)
EIU	Experiment Interface Unit	TEHM	Thermoelectric Holding Module
EOR/F	Enhanced Orbiter Refrigerator/Freezer	VCD FE	Vapor Compression Distillation Flight Experiment
EPDB	Emergency Power Distribution Box	WSA	Water Separator Assembly
ERISTO	European Research in Space and Terrestrial Osteoporosis	ZCG-1	Ziolite Crystal Growth-1
ESA	European Space Agency		
FAST	Facility for Adsorption and Surface Tension		
FCE	Flight Crew Equipment		
FD	Flight Day		
FREESTAR	Fast Reaction Experiment Enabling Science Technology Applications and Research		
FRESH-2	Fundamental Rodent Experiments Supporting Health-2		
FRR	Flight Readiness Review		
GLS	Ground Launch Sequencer		
ICD	Interface Control Document		
IFA	In-Flight Anomaly		
JSC HLS	Johnson Space Center Human Life Sciences		
KUSP	Ku-Band Signal Processor		
L•	Launch minus (hours or days)		
LCC	Launch Commit Criteria		
LDM	Logistics Double Module		
LOS	Loss of Signal		
LPT	Low Power Transceiver		
LSM	Logistics Single Module		
LSP	Laboratory Support Processor		
LSP	Laminar Soot Processes		
MECO	Main Engine Cut-Off		
MEIDEX	Mediterranean Israeli Dust Experiment		